

Keysight Technologies

Precise Current Profile Measurements of *Bluetooth*[®] Low Energy Devices using the CX3300

Application Brief

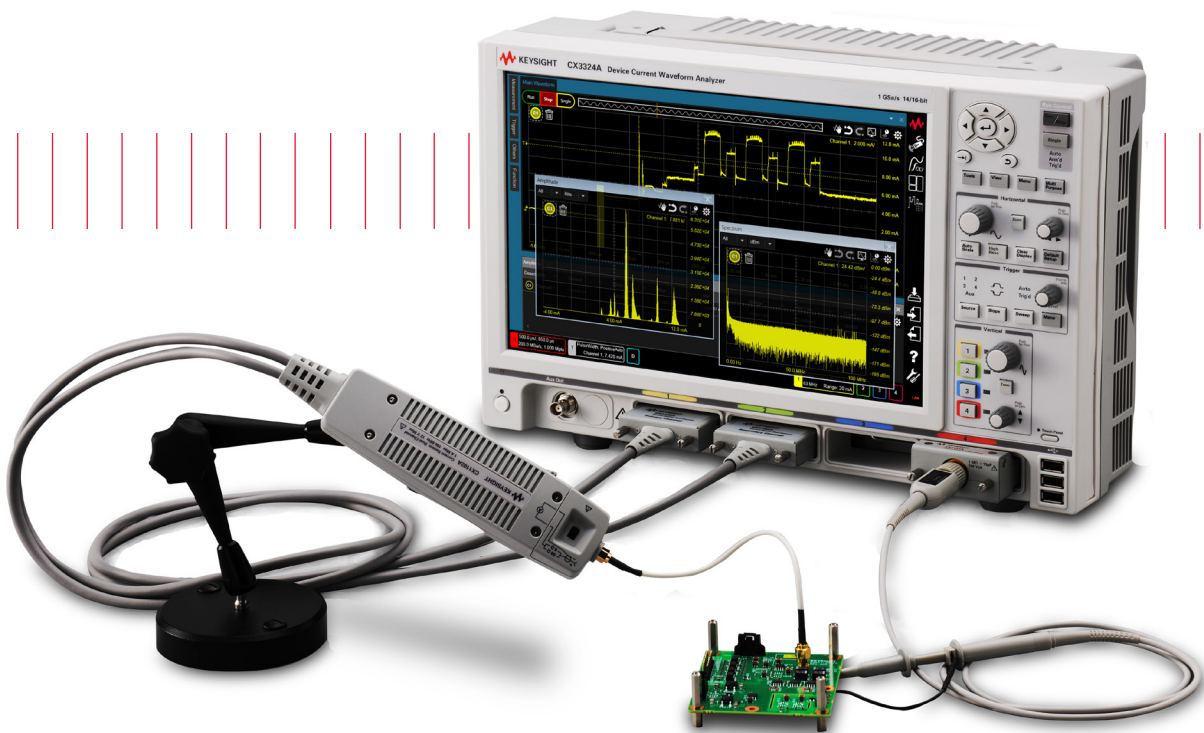



Introduction

New information technology, the Internet of Things (IoT) is changing our lives. The *Bluetooth*® low energy (BLE) standard is aimed at IoT applications and dramatically extends battery life. In order to implement it, there is a need to reduce the amount of unused power from existing devices, and Engineers are therefore exploring component level dynamic current consumption, which is difficult to measure, especially for low-power devices used in IoT enabled products, because of the limited dynamic range, large measurement noise and limited bandwidth.

The CX3300 series of Device Current Waveform Analyzers allows you to visualize wideband low-level, previously unmeasurable or undetectable, current waveforms. The mainframe has either 2 or 4 channels to receive signals from the Current Sensors and digitize them by a maximum of 1 GSa/s and a 14-bit or 16-bit wide dynamic range. There are three types of Current Sensors that can detect a wide range of dynamic currents from 150 pA level up to 10 A, with a maximum of 200 MHz bandwidth.

The CX3300 series also features useful analysis capabilities such as an Automatic Power and Current Profiler, a Power Measurement Wizard, FFT Analyzer and Statistical Analysis functions, which accelerate the analysis of the measurement data without the need to use external analysis utilities.

With this new and powerful analyzer, you can achieve critical mission on power and current consumption reductions by precisely measuring, previously unmeasurable or undetectable, wideband low-level current waveforms.

Problems with Present Solutions

In order to meet the demands for power consumption reduction, precise dynamic current waveform measurement and debug must be required. However, there are a number of difficulties to be resolved as follows:

- Limited dynamic range
For example, most of the battery-powered devices have low power sleep mode that consumes very little supply current such as less than 1 μA , while the active mode usually requires more than 10 mA current. It is difficult to measure such a wide dynamic range of currents with a single measurement.
- Large measurement noise.
Clamp-on type current probes are widely used, but measuring low-level current less than 1 mA is always difficult due to the large noise floor. Using a shunt resistor and an oscilloscope is very useful, but the minimum measurable current is limited due to the noise floor and the voltage drop across the resistor.
- Limited bandwidth.
Low-level current waveform measurements with a certain level of resolution need a tradeoff with bandwidth, otherwise wideband measurements may degrade the resolution. Using a multimeter or an ammeter is popular for high resolution measurements, but not appropriate for wideband current measurements due to the lower bandwidth.
- Multiple instruments required.
A multimeter is commonly used to measure the averaged sleep current, while the active current can be captured using an oscilloscope. The total power and current consumptions must be manually estimated from these results, but the data is not always reliable and it can be time consuming to validate it.

Solution

The CX3300 Series of Device Current Waveform Analyzers can solve the problems that engineers can be faced with when measuring the precise dynamic current of BLE devices. Table 1 shows the summary of CX3300's key features.

- A single measurement covers sleep to active mode with a 14 or 16-bit wide dynamic measurement range which clearly visualize even low-level current waveforms.
- The dynamic current waveform in sleep mode is now clearly visible by using the ultra-low noise current sensors.
- The narrow and sharp peak or spike current is captured by the wide bandwidth up to 200 MHz max bandwidth, 1 GHz max sampling rate and 256 MB memory depth so that you can easily eliminate any unexpected noise or other interferences.
- As well as capturing current waveform, the voltage passive probe can simultaneously capture voltage waveform, enabling you to precisely estimate the power consumption.
- Long learning periods for the user are eliminated thanks to intuitive touch screen based GUI and familiar functionalities.

Table 1 Key Features of the CX3300

Key Features	Specification
Current measurement range	150 pA to 10 A
Power measurement range	10 pW to 400 W
Maximum measurement bandwidth	200 MHz
Maximum sampling rate	1 GSa/s
Measurement dynamic range	14 or 16-bit ¹
Maximum memory size	256 Mpts/ch

1. 14-bit (High speed mode) or 16-bit (High resolution mode)

Measurement Setup Example

Figure.1 shows the block diagram of the I_{DD} measurement of a BLE device. The CX1101A Single Channel Current Sensor, which is one of the current sensors of the CX3300 and has maximum 100 MHz bandwidth, a current measurement range from 40 nA to 10 A and 40 V maximum voltage, is connected between the power supply and the DUT for current measurement.

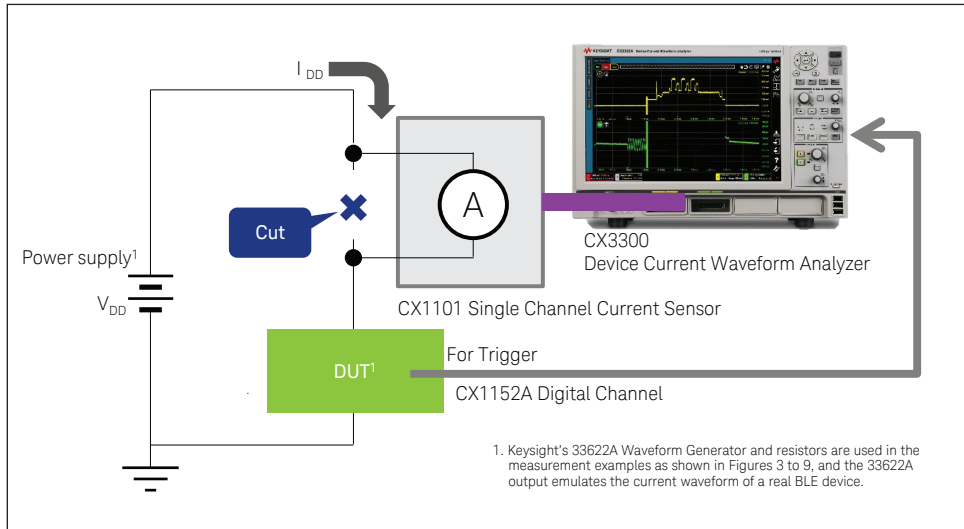

Figure 1. The block diagram of the I_{DD} measurement of a BLE device

You can find the best connection interface for your DUT from the six sensor head adapters that can be easily and safely attached to and detached from the CX1101A current sensor as shown in Figure 2. The SMA connector type adapters enable wideband measurements, while twisted pair and test lead adapters are useful for quick current waveform measurements that do not necessarily need a wide bandwidth.

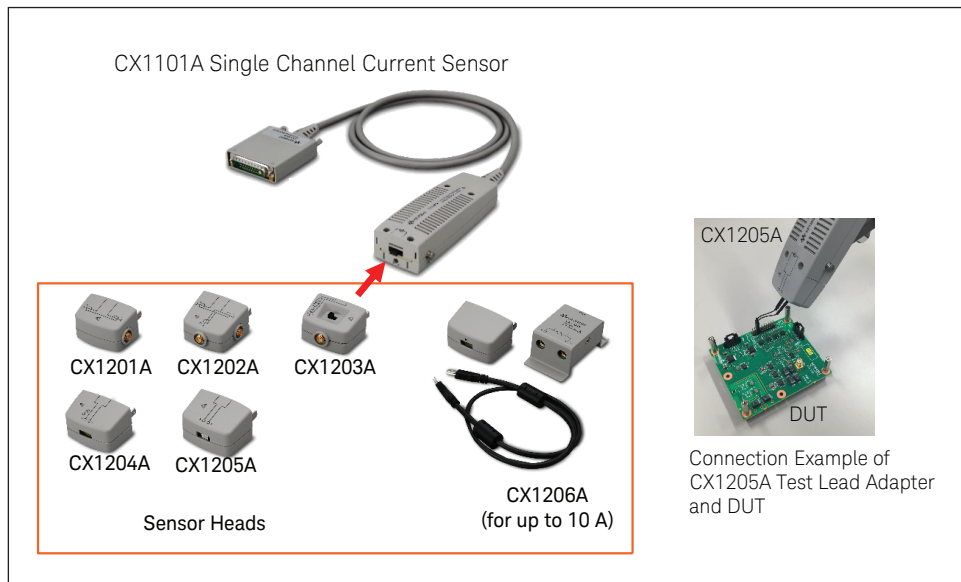

Figure 2. A wide variety of sensor head adapters provides the best connection interface for your DUT.

Measurement Examples

Figure 3 shows the current waveform measured using a CX1101A for simulated I_{dd} of an advertising event, from standby to advertising state of a BLE device. Up to ten milli-amperes flows during the active mode, but little current flows during the sleep mode. The current during sleep mode is quite small, but the device is in sleep mode most of the time, impacting on the total power consumption, and the precise current measurement during sleep mode is one of the key parameters when evaluating a BLE device. The current during active mode is also important for power consumption, because the current level is large. In addition, the precise current waveform during active mode is useful for the debugging of the operation on the circuit because it is altered by the various internal circuit operations such as a MCU, a DC-DC converter and other peripherals on the circuit. As shown in the Figure 3, due to the wide dynamic range, the CX3300 can cover from sleep to active mode with a one-time measurement. Figures 4 to 6 show the zoomed waveform of Figure 3 in more detail.

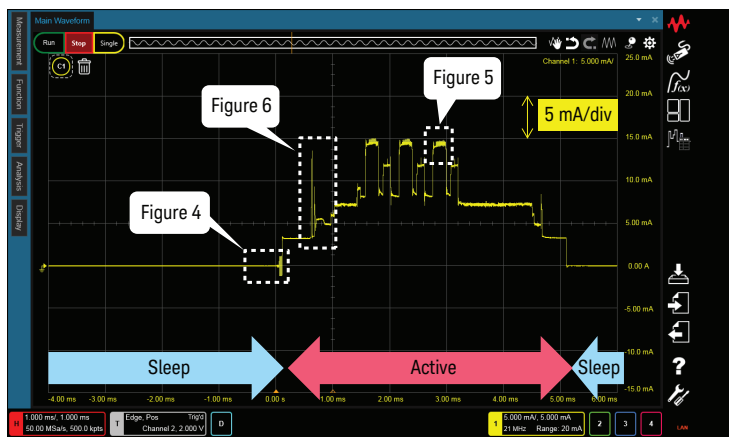

Figure 3. Current Profile Measurement Example of an advertising event

Figure 4 shows the zoomed current waveform of Figure 3 for both horizontal and vertical axis during sleep mode. This detail is possible to obtain by using the powerful zoom function of the CX3300 called the “Anywhere” zoom which allows you to zoom in on any area shown with a rectangular mark.

As shown in the 60 μ A peak-to-peak sine curve waveform of Figure 4, an actual BLE device can also have a periodic or non-periodic current because of the integrated switching converter pulse, sleep timer clock and so on, even in sleep mode. At one time, it was difficult to observe such current because no instruments were available with enough bandwidth, dynamic range and noise floor. Using the CX3300 it is possible to identify such characteristics because of its wider bandwidth, wider dynamic range and ultra-low noise floor.



Figure 4. Zoomed waveform at the sleep mode of Figure 3

Measurement Examples continued

Figure 5 shows the zoomed current waveform of Figure 3 during the active mode. Thanks to the 14 bit wide dynamic range, the small change in the large current is clearly observed as shown in the zoomed waveform. Such current waveform provides insight into the behavior of internal circuits and processes, and the CX3300 can be a very powerful tool for developing, debugging, and troubleshooting your products. The actual I_{dd} line would include many noises or an expected current spikes other than the target current caused by the noises from the power source, operation of other peripheral circuit, and so on. As shown in Figure 6, the CX3300 features various analysis functions such as FFT, histogram or post-filters, that help to obtain the target current waveform and isolate the cause of the noise or spikes.

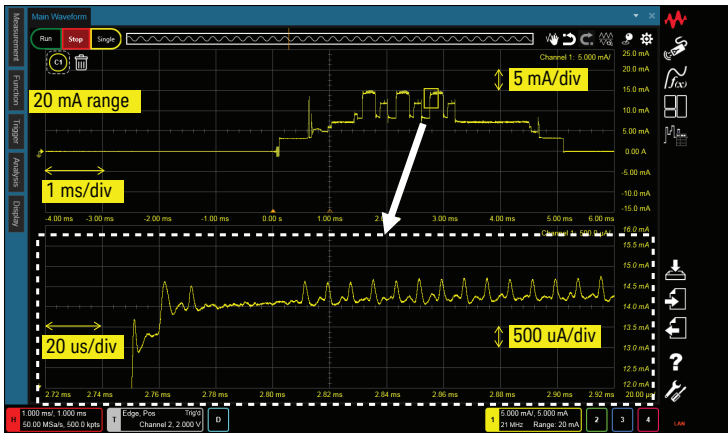

Figure 5. Zoomed waveform at the active area of Figure 3



Figure 6. An example of the Measurement & Analysis functions

Measurement Examples continued

Figure 7 shows the zoomed current waveform of Figure 3 at the wake-up area. Usually these spikes are suppressed by decoupling capacitors and not directly delivered to the power supply side. However, the current waveform without the decoupling capacitors could provide an insight into understanding what happens in the circuit for the purposes of design verification or trouble shooting. At one time, it was difficult to observe this kind of spike because of the limitations of the bandwidth and the resolution, however, the CX3300 has the capability to observe crisp detailed spike waveform due to its wide bandwidth and low noise front end.

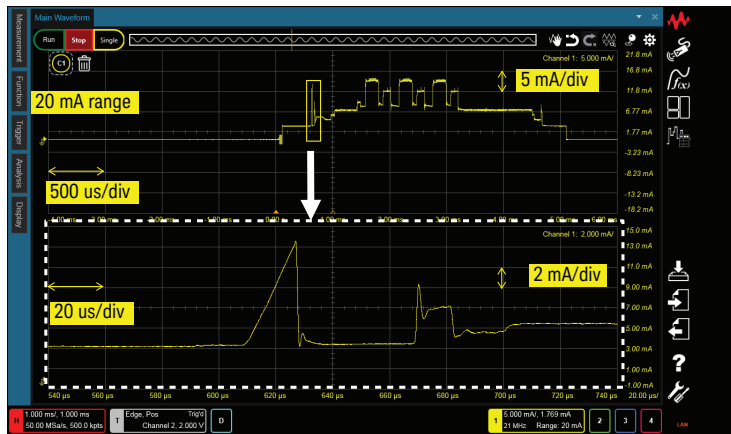

Figure 7. Zoomed waveform at the wake-up area of Figure 3

As shown in Figures 3 to 7, the CX1101A Single Channel Current Sensor has wide dynamic range that allows you to observe the current waveform from sleep to active mode. Furthermore, if wider dynamic range is required, the CX1102A Dual Channel Current Sensor is available. The CX1102A Dual Channel Current Sensor enables simultaneous measurements under two different measurement ranges. For example, the primary channel is set to a 200 mA range, while the secondary channel is set to a 2 mA range (primary channel range is 100 times more than secondary channel range). This current sensor is very useful for low-power applications that periodically operate in both sleep and active mode. Figure 8 shows the concept of the Dual Channel Current Sensor, it has two channel outs to provide simultaneous low- and high-gain views for wider dynamic range measurements.

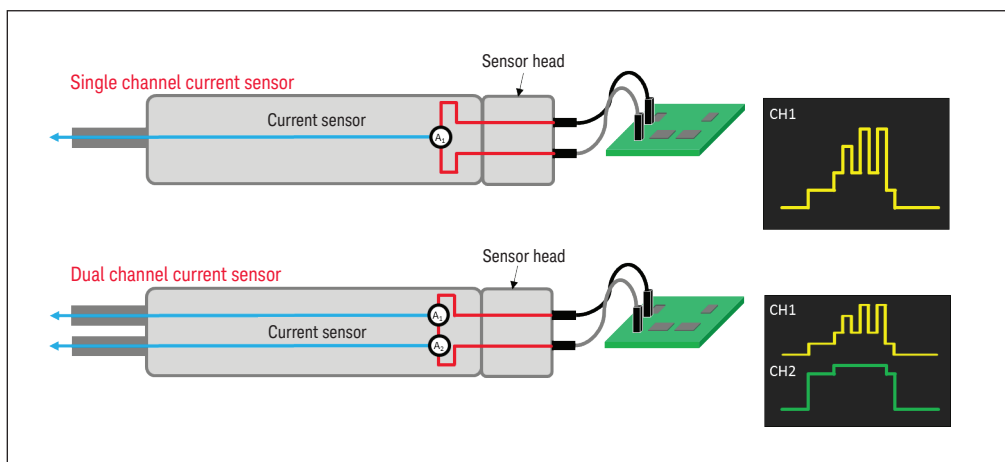

Figure 8. The concept of the Dual Channel Current Sensor

Measurement Examples continued

Figure 9 shows the same measurement as Figure 4 with the CX1102A. As shown in Figure 9, the CX1102A enables you to simultaneously measure a current waveform for both sleep and active mode.



Figure 9. Current Profile Measurement Example with CX1102A Dual Channel Current Sensor

The analysis of power or current profile is essential in order to know how much current is consumed at a certain event or status, but it is time-consuming process. As shown in Figure 10, the Automatic Power and Current Profiler functions can eliminate time-consuming power and current profile analysis. This profiler automatically draws lines in the time scale by the vertical level difference and instantly calculates key parameters such as average current, max. /min. current, accumulated charge, etc. for each segment in the adjacent table. You can also manually adjust the segment according to your measured profile.

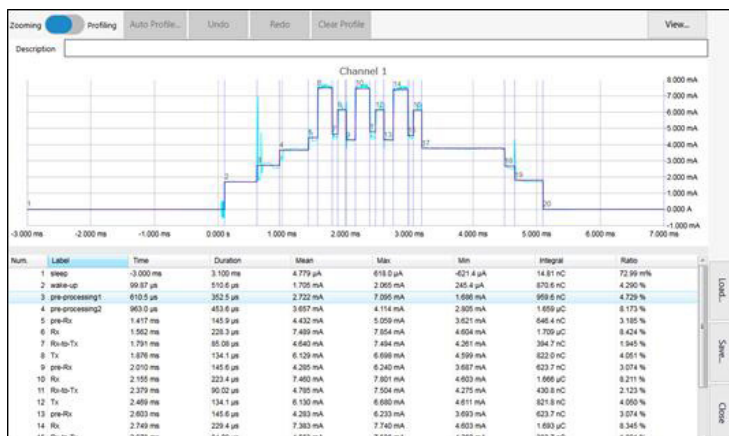

Figure 10. Automatic Power and Current Profiler

Conclusion

The CX3300 enables you to easily and accurately visualize wide-band and low-level current waveforms and make quantitative evaluations of current waveforms, while reducing the power consumption of BLE devices.

Useful analysis capabilities such as an Automatic Power and Current Profiler, a Power Measurement Wizard, a FFT Analyzer and Statistical Analysis functions, accelerate the analysis of the measurement data without the need for external analysis utilities.

Evolving

Our unique combination of hardware, software, support, and people can help you reach your next breakthrough. **We are unlocking the future of technology.**



From Hewlett-Packard to Agilent to Keysight

For more information on Keysight Technologies' products, applications or services, please contact your local Keysight office. The complete list is available at: www.keysight.com/find/contactus

Americas

Canada	(877) 894 4414
Brazil	55 11 3351 7010
Mexico	001 800 254 2440
United States	(800) 829 4444

Asia Pacific

Australia	1 800 629 485
China	800 810 0189
Hong Kong	800 938 693
India	1 800 11 2626
Japan	0120 (421) 345
Korea	080 769 0800
Malaysia	1 800 888 848
Singapore	1 800 375 8100
Taiwan	0800 047 866
Other AP Countries	(65) 6375 8100

Europe & Middle East

Austria	0800 001122
Belgium	0800 58580
Finland	0800 523252
France	0805 980333
Germany	0800 6270999
Ireland	1800 832700
Israel	1 809 343051
Italy	800 599100
Luxembourg	+32 800 58580
Netherlands	0800 0233200
Russia	8800 5009286
Spain	800 000154
Sweden	0200 882255
Switzerland	0800 805353
	Opt. 1 (DE)
	Opt. 2 (FR)
	Opt. 3 (IT)
United Kingdom	0800 0260637

For other unlisted countries:
www.keysight.com/find/contactus
(BP-2-23-17)

DEKRA Certified
ISO 9001 Quality Management System

www.keysight.com/go/quality
Keysight Technologies, Inc.
DEKRA Certified ISO 9001:2015
Quality Management System

This information is subject to change without notice.
© Keysight Technologies, 2016 - 2017
Published in USA, March 3, 2017
5992-1589EN
www.keysight.com

myKeysight

myKeysight
www.keysight.com/find/mykeysight
A personalized view into the information most relevant to you.

KEYSIGHT SERVICES

Accelerate Technology Adoption.
Lower costs.

Keysight Services
www.keysight.com/find/service
Our deep offering in design, test, and measurement services deploys an industry-leading array of people, processes, and tools. The result? We help you implement new technologies and engineer improved processes that lower costs.



Three-Year Warranty
www.keysight.com/find/ThreeYearWarranty
Keysight's committed to superior product quality and lower total cost of ownership. Keysight is the only test and measurement company with three-year warranty standard on all instruments, worldwide. And, we provide a one-year warranty on many accessories, calibration devices, systems and custom products.



Keysight Assurance Plans
www.keysight.com/find/AssurancePlans
Up to ten years of protection and no budgetary surprises to ensure your instruments are operating to specification, so you can rely on accurate measurements.

Keysight Channel Partners
www.keysight.com/find/channelpartners
Get the best of both worlds: Keysight's measurement expertise and product breadth, combined with channel partner convenience.

The Bluetooth® word mark and logos are registered trademarks owned by Bluetooth SIG, Inc.

<http://www.ccontrols.ch/deutsch/News/Keysight-CX3300-Series-Device-Current-Waveform-Analyzer.html>

www.keysight.com/find/cx3300